

MOTOR SPECIFICATION SHEET

MODEL : SC-QR 1/3HP 4P

USED FOR : STANDARD

DESCRIPTION	DETAIL			
PHASE	1			
TYPE	CAPACITOR START			
MODEL NAME	SC-QR			
RATED OUTPUT, HP (kW)	1/3 (0.25)			
POLE	4			
CODE	MEATH CODE : 1M001C-400030QRER1			
OUTLINE DRAWING NO.	ONM74O091-*			
RATED VOLTAGE (V)	220	230	220	
RATED FREQUENCY (Hz)	50	50	60	
RATED CURRENT (A)	3.1	3.2	2.8	
RATED SPEED (min ⁻¹)	1450	1450	1740	
RATED EFFICIENCY (%)	64.9	63.5	69.6	
THERMAL CLASS	120(E)			
RATING	S1 (CONTINUOUS)			
ENCLOSURE CONSTRUCTION	OPEN-PROTECTED			
DEGREES OF PROTECTION	IP20			
METHOD OF COOLING	IC01			
FRAME NO.	B71			
WEIGHT (kg)	7.6			
STANDARD	JEC-2137-2000			
EFFICIENCY RULE	IEC 60034-30-1			
INSTALLATION	FOOT MOUNTED			
ROTATION	CCW (VIEWED FROM SHAFT END)			
BEARING	LOAD SIDE : 6202ZZ			
	OPPOSITE SIDE : 6201ZZ			
BEARING GREASE	UREA GREASE			
VIBRATION	V20			
CIRCUMSTANCE CONDITION	AMBIENT TEMPERATURE : -20 ~ +40°C			
	AMBIENT HUMIDITY : 85%RH OR LESS			
	ABOVE SEA LEVEL : 1000m OR LESS			
	ENVIRONMENT : NO BURSTING/EROSIVE GAS OR VAPOR			
COLOR	MUNSELL N1.5 (BLACK)			
TERMINAL BOX	NO. OF LEAD WIRES : 2			
	SOURCE CONNECTION : TERMINAL BLOCK			
INSULATION RESISTANCE	BY DC 500V MEGGER - ≥100MΩ			
DIELECTRIC TEST	AC 50Hz 1500V - 1min. (Based on rated voltage 220V)			
SHAFT SWING	≤0.03mm			
MATERIAL	FRAME : STEEL PLATE			
	BRACKET : STEEL PLATE			
	SHAFT : CARBON STEEL			
	STATOR CORE : ELECTRICAL STEEL			
	WIRE : ENAMELLED COPPER MAGNET WIRE			
	INSULATOR : POLYESTER FILM			
	VARNISH : EPOXY DENATURALIZATION POLYESTER			
	ROTOR CORE : ELECTRICAL STEEL			
	CONDUCTOR : ALUMINIUM			
	TERMINAL BOX : PLASTIC			
	PAINTING : ALKYD-NITROCELLULOSE RESIN			
PRODUCTION COUNTRY	THAILAND			

Specifications subject to change without notice.

SPECIFICATION SHEET NO.				
SS-M-7301-B				

MODEL SC-QR SINGLE PHASE INDUCTION MOTOR OUTLINE DRAWING

CAPACITOR START TYPE
DEGREE OF PROTECTION IP20

STARTING CAPACITOR	80 μ F 250 V
RUNNING CAPACITOR	-

CUSTOMER	_____
USER	_____
FOR	_____
CUSTOMER'S ORDER NO.	_____
QUANTITY	_____
MFG. ORDER NO.	_____

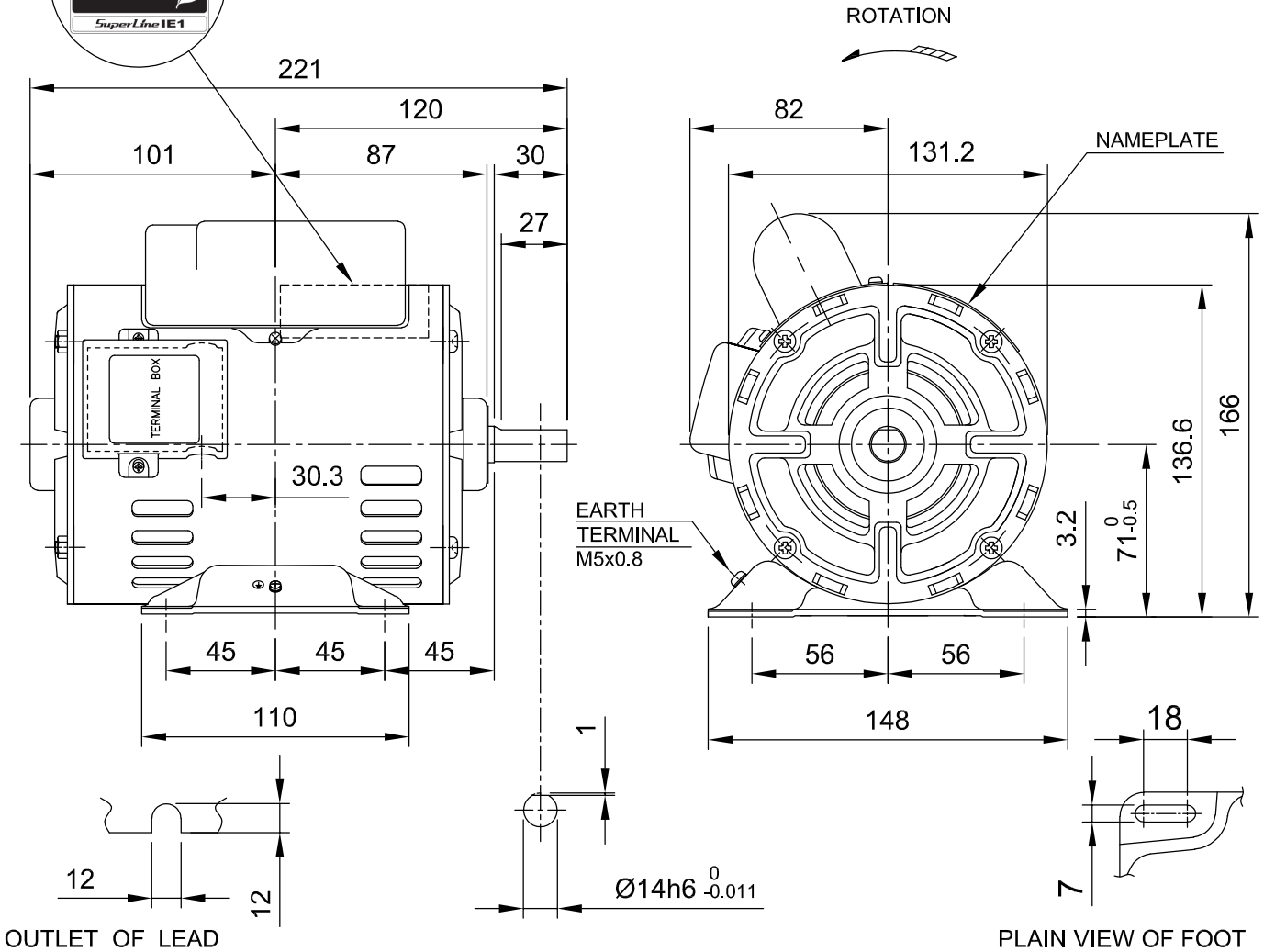

FRAME SIZE	RATING	TH. CLASS	AMB. TEMP.	BEARINGS		COLOR	DIRECTION OF ROTATION	NO. OF LEAD WIRES
				LOAD SIDE	OPP. SIDE			
B71	S1	120(E)	40°C	6202ZZ	6201ZZ	BLACK (MUNSELL N1.5)	CCW	TERMINAL BOARD

OUTPUT		POLE	Hz	VOLT	AMP	RPM	IE CODE - RATED EFF.	REMARK
HP	kW							
1/3	0.25	4	50	220/230	3.1/3.2	1450/1450	IE1- 64.9% / IE1- 63.5%	
			60	220	2.8	1740	IE1- 69.6%	

MITSUBISHI ELECTRIC AUTOMATION (THAILAND) CO.,LTD.

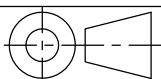

DIMENSION IN mm.
SCALE : NTS.

OUTLINE DRAWING NO.

ONM740091

REV.

